

SADE SP-B60 Benchtop

Weight Sorter/Checkweigher for tablets, capsules, soft-gels and mini-tabs

COMPACT BENCHTOP

Ideal for the busy R&D laboratory

Designed for the 100% weight sorting of development or clinical trial batches the compact SADE SP-B60 Benchtop unit is ideal for the laboratory environment. Each item is individually weighed to a high accuracy and sorted into accept or reject categories.

This versatile unit handles a wide range of solid dose forms without the need for any size or change parts. The unit is also quick and easy to dismantle for cleaning and simple to set up ready for the next product.

With the SADE SP-B60 the product to be weight sorted can be manually loaded directly into the bowl feeder. Or, with the optional mini bulk hopper fitted product is automatically fed into the bowl feeder. This boosts efficiency by providing periods of unattended operation thus freeing operators for other tasks.

R&D – ensuring weight consistency

- 100% weight checking and statistical analysis of development batches
- Saves manual weight checking

KEY FEATURES

- Sorts tablets, capsules, soft gels and mini-tabs
- Handles all shapes and sizes
- High accuracy $\pm 1\text{mg}$ or $\pm 0.5\text{mg}$
- Simple to operate
- Quick and easy clean down
- Unattended operation with mini bulk-hopper option
- Data integrity – full 21CFR Part 11 and Annex 11 compliance
- Full audit trail
- Domain authentication available
- OPC UA data protocol available



weight
sorting

SADE SP-B60 Benchtop

Weight Sorter/Checkweigher for tablets, capsules, soft-gels and mini-tabs

KEY OPERATIONAL BENEFITS

Our SADE SP units are already delivering precision weight sorting to the world's leading pharmaceutical developers across the globe.

Informed decision making and action taking

- Touch screen controller with real time display of statistical data
- Prints detailed reports – local or network printer

KEY OPTIONS

Mini hopper

boosts unit efficiency with periods of unattended operation

Longer chutes

enable the unit to be located on the edge of a bench to utilize larger accept and reject containers.

Comprehensive documentation

detailed technical, validation, IQ/OQ documentation

Material certificates

for quality stainless contact parts

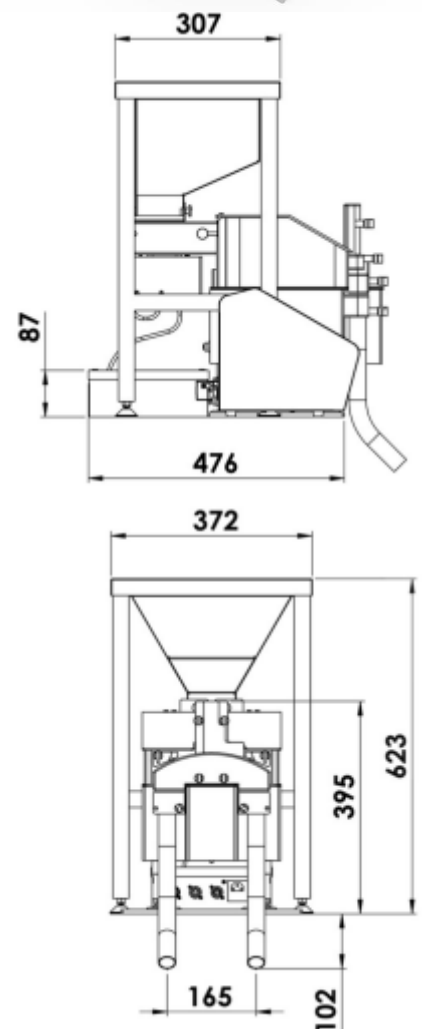

TECHNICAL DETAILS

Mounting	Benchtop
Weighing Channels	1
Sorting Groups	2 (Accept and Reject)
Sorting Rate	Up to 70 - 75 items per minute Up to 4000 - 4500 items per hour Sorting rate varies per product & environment
Hopper Capacity (optional)	9.5 litres
Weight Range	Up to 2 grams
Product Size	Tablets: Up to 24mm length, 20mm wide Capsules: 00, 0, 1, 1el, 2, 2el, 3, 4, 4el, 5 (Size 000, 00el available on request Contact CI Precision for details)
Balance Readability	0.1 mg
Reproducibility	±1mg (user selectable option of ±0.5mg)
Zero System	Automatic
Contact Parts	316/316L electro-polished stainless steel and PEEK (polyetheretherketone FDA 21CFR 177.2415)
Dimensions (mm)	Full dimensions available on request
Voltage & Frequency	115/230 VAC 50/60 Hz
Air Supply	Clean dry air 3-4 bar or 43-73PSI



Brunel Road, Churchfields
Salisbury, Wiltshire
SP2 7PX United Kingdom

T +44 (0)1722 424100
E sales@ciprecision.com

www.ciprecision.com