

Gericke

Powder Processing Equipment and Systems

Precision Feeders

High accuracy feeding solutions for industrial processes



**Volumetric Feeders
for bulk materials**

Feeding – At the centre of total process control



Controlled feed into a Gericke continuous mixer

Proven designs with thousands of running applications.

Gericke volumetric feeders are designed for throughputs from 0.05 to 50,000 litres per hour for most dry solids and liquid applications.

Gericke's range of feeders are based upon a robust modular design which are used in almost all processing applications including:

- **Chemical**
- **Foods**
- **Pharmaceutical**
- **Construction Minerals**
- **Plastics**
- **Detergents**

Gericke – Feeding of bulk material since 1894.

Gericke offer cost effective feeding solutions for most powders, granules, fibres, flavours, pigments and liquids.

Added Benefit:

Expert advice on correct selection and operation of the unit, prompt after sales support by specialist engineers, secure return on investment.



*GLD 87 VR;
Compact feeder suitable
for a wide range of mate-
rial characteristics*

Modular feeding equipment – designed for process flexibility

Volumetric feeding



The feed rate is measured by volume against time.

A reliable volumetric device is essential for a high accuracy gravimetric weigh feeder.

Accurate metering of bulk solids is achieved using a spiral helix, rotary valve, rotating agitator, vibrating tray or cylindrical stator. Even in the volumetric mode, the metering rate remains constant under the condition of a repeatable fill level within of the selected feeding tool and an even bulk density of the powder.

Gravimetric Feeding



The feedrate or batch weight is regulated by the process controller.



Using a gravimetric feeder with load cells, a batch weight can be accurately dispensed or the feed rate continuously controlled. The mode is dependent on the process requirements.

Gericke can upgrade most volumetric feeding models into Gravimetric devices.

The right feeder for each specific application

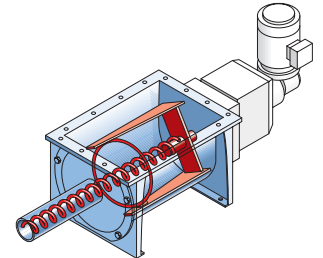
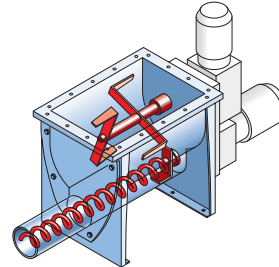
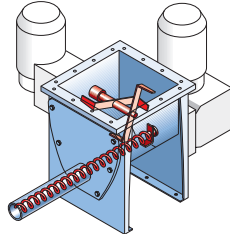
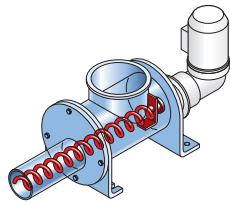

GPD

Low cost, efficient feeder

Application:

Free flowing dry materials for lower feed rates

Advantages:

Quick and simple to dismantle for wet and dry cleaning, light weight unit (9 Kg)

Capacity range*:

0,05–600 l/h

Type:

GPD 100

GLD

Compact feeder with agitator for high accuracy feeding

Application:

Suitable for most dry solids, pilot plants, frequent product changes

Advantages:

Versatile, adaptable, compact, reliable, precise

Capacity range*:

0,05–600 l/h

Type:

GLD 77 (mechanical agitator),
GLD 87 (agitator with independent drive)

GDU

Universal feeder, minimal product retention, used for poor flowing materials

Application:

Medium to high capacity feed rates, hygienic design, difficult products, high feeding accuracy, raisin and fruit feeders, (special applications)

Advantages:

Versatile, adaptable, complete emptying

Capacity range*:

1,3–25.600 l/h
(depending on model)

Type:

GDU 201, GDU 451, GDU 801
(with agitator),
GDU 301, GDU 601
(without agitator)

GAC

Universal Feeder for highest accuracy, homogeneity and distribution of bulk materials

Application:

Medium to high feed rates, very difficult materials, highest feeding accuracy batch weighing & feeding station (GAC 233F)

Advantages:

Feeding tool and homogeniser are concentrically aligned with large product entry suitable for difficult products

Capacity range*:

1,3–27.000 l/h

Type:

GAC 207, GAC 232;
GAC 233 F (with separate helix for coarse and trickle feeding)



GPD 100



GLD 87



GDU 451



GAC 207

Technical advantages of Gericke feeders:

- Robust construction
- High reliability for long life cycle
- Hygienic design (in accordance with EHEDG)
- Large range of feed tool lengths
- No segregation
- Large entry section
- Constant bulk density
- Crevice free surfaces
- Continuous welding (option)
- Range of drive options
- +/- pressure rated options available

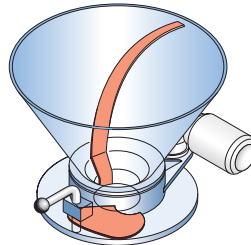
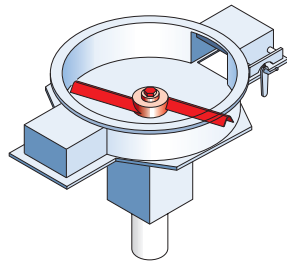
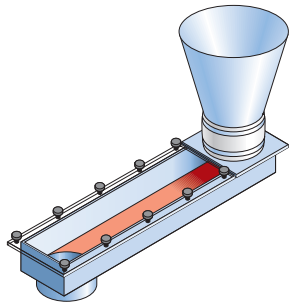

VIBRO

Vibro feeder for coarse and fragile products

Application:

Large capacity range, fragile or abrasive products, light and coarse materials, fibres

Advantages:

No rotating parts, gentle operation, easy cleaning, no component wear

Capacity range*:

1–10000 l/h

RA

Discharge and feeding device for very poor flowing products. A rotating paddle sweeps the product towards the outlet valves. An adjustable valve regulates the feed rate

Application:

Discharge from silo's or hoppers, refilling loss-in-weight feeders, component feeding

Advantages:

Discharge without segregation, feed-distribution (1 – 4 outlets) and shut off valve combined into one device

Capacity range*:

0,2–40.000 l/h

Type:

RA 500, RA 800, RA 1200, RAS (RAS Type for over/under pressures)

KAD

Discharge and feeding device. An agitator moves the product towards the outlet. The slide gate regulates the feed rate.

Application:

Filling systems, can be combined with automated batch controller

Advantages:

Combined discharge and feeding, hygienic, easy to clean, high feeding accuracy

Type:

KAD 90 (Outlet diameter 1–90 mm), KAD 150 (Outlet diameter 1–150 mm)



The benefits:

- Easy cleaning
- High feeding accuracy
- Guaranteed recipe reliability
- Versatile applications
- Low maintenance costs
- Simple to control
- Adaptable (easily adaptable)



Vibro feeder



RA with 1–4 outlets



KAD discharge and feeding device

ISO 9001:2000

ISO 9001-2000 quality guarantee
Gericke is a member of EHEDG

Selecting the correct feeding tool

Product Characteristics



- free flowing (*salt, corn, sugar*)
- flushing (*carbonates, fly ash, gypsum*)
- fluidisable (*cocoa*)
- cohesive (*TiO₂, stearates*)
- adhesive (*carbon black, pigments*)
- abrasive (*quartz sand, silicon carbide*)
- compressible (*chalk*)
- fragile (*flakes, instant coffee*)

Installation

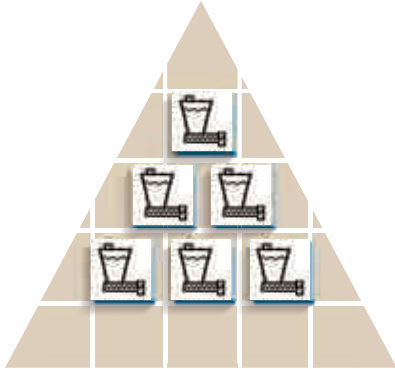

- Mounting (supported or hinged)
- Number of feeders
- Headroom
- Feed distance

Process



- Capacity
- Operation mode (batch/continuous)
- Pressure rating
- Accuracy
- Level of automation

Feeding tool selection

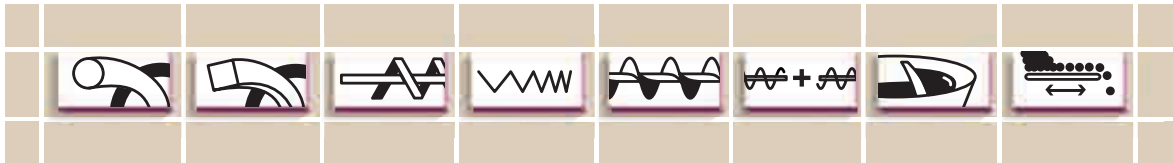

- Round spiral
- Square helix
- Helix with centre shaft and end bearing
- Variable pitch
- Full flight screw
- Vibro feeder
- Extended feed tool
- Fluidisation
- Rotating bin discharger

Accessories for high feed accuracy	Agitator	→ consistent product flow
	Homogeniser	→ repeatable bulk density for optimum feed accuracy
	Bridge breakers	→ Ensure difficult products discharge for the surge hopper into the feed chamber

Ancillary process equipment

Gericke feeders are designed using a modular system customised to the specific requirements of the application. The flexibility of the Gericke equipment range offers simplified system design and greater added value.

- Special designs for agitators and homogenisers
- Surface finish and coatings; EGPDFE, Bead blast, electro-polished
- Variable feed tool lengths
- Shaft seals: stuffing box, PTFE lip seals, air purge glands
- AR outlet for vertical discharge
- ARFE outlet, flanged with end bearing
- ARFG outlet with "Granuflow" flow control
- AGP shut off valve with position indicator
- Hinged bottom door with safety switch
- FDA approved seals

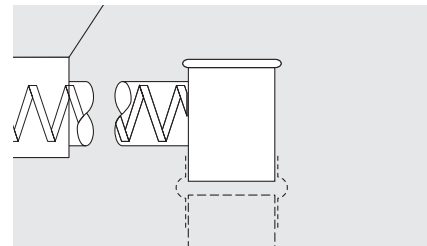

Type AR vertical outlet connection

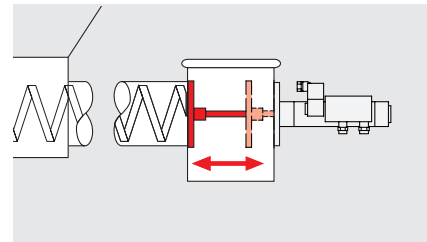

AGP outlet for instant product shut off (optional position indicator)



Semi-automated feeding station for accurate dosing into various sacks and boxes

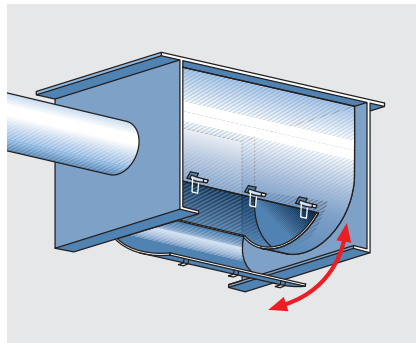

GAC feeder with hinged door for quick cleaning

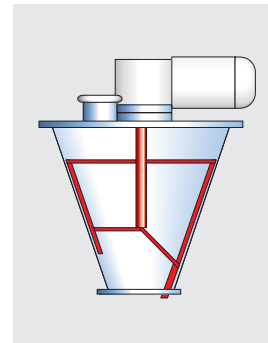

Hopper with vertical agitator

- Drive options
- Variable speed integrated frequency inverter
- Pressure tight design
- High temperature applications
- ATEX zones: 1, 2, 22, 21
- Special feeders for raisins and fruits.
- Pneumatic conveying feeder refill systems



GDU 601 with extended feed screw

Selection of reference products

Density kg/l

A			
Activated Charcoal	0.21	Manganese Ore	1.8
Acrylic Resin (Fibres)	0.14	Marble Chips	1.5
Acrylic Resins (Granulated)	0.51	Marble Dust	1.2
Additives	0.2-0.4	Metallic Powder	3.04
Adipic Acid	0.62	Mica Flakes	0.16
Aerosil	0.046	Milk Powder	0.58
Aluminium Chloride	0.59	Molybdenum Oxide	1.82
Aluminium Flakes	1.30	N	
Aluminium Fluoride	1.22	Nuts	0.41
Aluminium Oxide	0.90	Nylon (Fibres)	0.16
Aluminium Powder	1.30	Nylon (Flakes)	0.52
Aluminium Silicate	0.54	Nylon (Granules)	0.57
Aluminium Sulphate	0.90	Nylon (Powder)	0.63
Ammonium Nitrate	0.62	O	
Ammonium Phosphate	0.83	Oat Cream Powder	0.57
Antimony Oxide	0.69	Oat Flakes	0.45
Apple Pectin	0.51	Oat Flour	0.39
Ascorbic Acid	0.55	Onion (Chopped)	0.24
B		Onion(Powder)	0.41
Barium Carbonate	0.17-1.4	Ores	1.4-2.6
Barium Stearate	0.23	Oxalic Acid	0.85
Barium Sulphate	1.45	P	
Barley Flour	0.63	Peppercorn	0.27
Bauxite	1.2	Perlite (Expanded)	0.12
Borax	0.97	Perlite (Rock)	1.17
Brick Dust	1.2	Perlon Wool	0.25
C		Pesticide	0.4-0.6
CaB-O-Sil	0.03	Phenol Resin (Powder)	0.54
Calcium Carbonate	1.2	Pigments	0.2-1.0
Calcium Chloride	0.97-1.1	Polyethylene (Granules)	0.57
Calcium Stearate	0.39	Polyethylene (Powder)	0.67
Calcium Sulphate	0.74	Poly-Electrolyte	0.5-0.7
Carbon Black	0.4	Polyester Chips	0.15
Casting Powder	0.69	Polyester Resin (Flakes)	0.4
Celite	0.25	Polypropylene (Granules)	0.5
Cellulose Acetate	0.13	Polypropylene (Powder)	0.54
Cement	1.2	Polystyrene (Expanded)	0.1
Ceramic Mixture	1.4	Polystyrene (Granules)	0.6
Charcoal Powder	0.40	Polystyrene (Powder)	0.65
Chicory Powder	0.49	Polyvinyl Chloride (Granules)	0.62
Chocolate Powder	0.65	Potash (Flakes)	0.5
Cinnamon Sugar	0.74	Potassium Permanganate	1.1
Citric Acid	0.8	Potassium Sulphate	2.25
Coal Dust	0.59	Potato Flour	0.7
Cocoa Beans	0.56	PTFE (Granules)	0.53
Cocoa Powder	0.5	PTFE Powder (Algoflow)	0.51
Coffee Beans	0.39	PVC Floor Covering Chips	0.6
Coffee Powder	0.18	PVC Powder	1.0
Corn	0.6	Q	
Cornflour	0.74	Quartz Powder	1.2
Corn Starch	0.48	Quartz Sand	1.5
D		R	
Dacron	0.51	Rice	0.94
Dextrose	0.57	Rice Crispiers	0.11
Detergents	0.3	Rubber (Chips)	0.4
Diatomite	0.08-0.25	Rubber (Granules)	0.46
Dyestuffs	0.25-0.75	S	
E		Salt	1.18
Egg Powder	0.35	Sand	1.6
Electrode Carbon	1.0	Sawdust	0.29-0.45
Epoxy Resin Powder	0.8	Silica - Gel	0.25
F		Silica	1.05
Feedstuffs (Animal)	0.49	Silica Acid (Powder)	0.23
Ferric Chloride	1.6	Sipernat	0.22
Ferric Oxide	0.87-1.3	Slag	0.4
Felspar	1.2-1.8	Slag Wool	0.09
Ferrasil	0.98	Soap Flakes	0.47
Fibres-Glass Fibres	0.2	Soap Powder	0.58
Filtration Aids	0.23	Soda	1.0
Filter Cakes	0.65	Sodium Bicarbonate	0.98
Fish Food	0.77	Sodium Chloride	1.18
Flavourings	0.33	Sodium Nitrate	1.35
Flue Ash	1.06	Sodium Perborate	0.78
Flue Dust	1.30	Sodium Tripolyphosphate	0.78
Foam Plastic Flakes	0.011	Spice Mixture	0.75
Foam Rubber	0.05	Spinach Powder (Dry)	0.42
Foam Shavings	0.25	Stabilisers	0.4
Fungicide	0.41	Starch Granules	0.75
Fullers Earth	0.35-0.6	Starch Powder	0.67
G		Stearic Acid	0.55
Garlic Powder	0.33	Styropor Pellets	0.58
Gelatine	0.74	Sucrose	0.54
Glass (Ground)	1.7	Sucrose (Crystalline)	0.81
Glass (Splinters)	1.65	Sugar (Crystalline)	1.02
Glass (Fibres)	0.2	Sugar (Powder)	0.62
Glass (Frit)	1.95	Sugar (Raw)	0.81
Glass (Beads)	0.4	Synthetic Wax Powder	0.42
Glazing Mixture	0.62	Synthetic Resin Granules	0.55-0.65
Glue Powder	0.6	Synthetic Resin Powder	0.65-0.75
Graphite (Granules)	1.12	T	
Graphite (Powder)	0.58	Talcum	0.46
Graphite (Salt)	0.5	Tea	0.39
Grass Seed	0.16	Teflon Fibres	0.49
Grinding Powder	2.3	Terephthalic Acid	0.49
Gypsum	0.9	Textile Fibres	0.14
Gypsum Calcined	1.2	Titanium Dioxide (White)	0.79
Gravel	1.4-1.7	Tobacco (Cigarettes)	0.19
H		Tobacco (Leaf)	0.1
Herbicide	0.4-0.6	Tri-Calcium Phosphate	0.49
I		Tri-Sodium Phosphate	0.75
Insecticide	0.4-0.6	Triphosphate	0.55
Iron Powder	3.5	Tungsten Carbide	3.28
Iron Sulphate	1.3	V	
K		Varnish Powder (Course)	0.98
Kaolin (dry)	0.8	Vinyl Resin (Granules)	0.6
L		Vinyl Resin Powder	0.57
Lime (Quick)	0.9	Vitamins	0.45-1.0
Lime (Slaked)	0.62	W	
Limestone (Crushed)	1.35	Washing Powder	0.3
Limestone (Flour)	1.25	Wheat Flour	0.64
M		Wood Shavings	0.17
Magnesium Carbonate	0.25	Z	
Magnesium Oxide	0.62	Zinc Granules	4.0
Magnesium Stearate	0.34	Zinc Oxide	0.98
Malt Flour	0.63	Zinc Stearate	0.22
MalTED Milk	0.53		
Manganese Dioxide	1.08		

World-wide Service Support

Material reference chart:

The stated values are for indicative purposes only and are subject to confirmation after receipt of all application details. Planning drawings are available in dxf format from the Gericke web-site www.gericke.net.

Type	Feed capacity range l/h*	Drive kW	Weight kg	Height, Width, Length (including drive and feed device) mm	Specials
GPD 100	0,05 - 600	0,12	9	270, 150, 480	without agitator
GLD 77	0,05 - 600	0,12	12	350, 200, 540	mechanical agitator
GLD 87	0,05 - 600	0,12	18	350, 350, 540	with independent drive
GAC 207	1,3 - 4.800	0,55	75	500, 290, 1110	homogenising
GAC 232	1,3 - 27.000	0,55	90	540, 390, 1260	homogenising
GAC 233 F	batch operation	0,55	140	450, 400, 1400	2 feedworms
GDU 201	1,3 - 800	0,55	50	340, 420, 1000	minimal product retention
GDU 301	1,3 - 11.200	0,55	40	280, 290, 1100	without agitator
GDU 451	10 - 11.200	0,55	100	680, 390, 1200	minimal product retention
GDU 601	10 - 25.000	0,55	50	360, 390, 1400	sack tipping
GDU 801	500 - 50.000	3,0	450	910, 1150, 2000	difficult powder
Vibro	0,5 - 10.000				
KAD150	batch operation	0,37	40	900, 510 diameter	conditioning
RA 500	400 - 40.000	3,0	100	ca. 600 diameter	1-4 outlets
RA 800	400 - 80.000	5,5	150	ca. 900 diameter	1-4 outlets
RA1200	400 - 100.000	200	200	ca. 1300 diameter	1-4 outlets

*Approximate throughput values based on Semolina. Minimum value using smallest helix diameter at 5% of speed range and maximum value with largest helix at 100%



Feeding and sifting station for Pharmaceutical powders

Gericke feeders are used in a vast variety of production applications including: ice tea, syrups, spices, mustard, milk powder, cereal bars, pizza toppings, gypsum boards, salt, ceramics, metal coatings, PVC powder and many more.

Gericke

Powder Processing Equipment and Systems

GB-Ashton u. Lyne OL6 7DJ
Tel. +44 (0)161 344 1140
Fax +44 (0)161 308 3403
gericke.gb@gericke.net

CH-8105 Regensdorf
Tél. +41 (0)44 871 36 36
Fax +41 (0)44 871 36 00
gericke.ch@gericke.net

Singapore 787813
Tel. +65 (0)64 52 81 33
Fax. +65 (0)64 52 03 92
gericke.sg@gericke.net

F-95100 Argenteuil
gericke.fr@gericke.net

NL-3870 Hoevelaken
gericke.nl@gericke.net

D-78239 Rielasingen
gericke.de@gericke.net

<http://www.gericke.net> info@gericke.net

For further information about gravimetric feeders and controllers please request the Gericke leaflets No 624 **Easydos** and No 625 **Gravimetric feeders**.

We will be pleased to forward copies or alternatively they can be downloaded for our website www.gericke.net